



WAFER BUTTERFLY VALVES



PVC Quick-View Valve Selection Chart

Valve Size	O-ring Material	STANDARD VALVE DESIGN			Pressure Rating
		PVC Part Number ¹			
		w/Lever Handle	w/Gear Operator	Valve Only	
2	Buna-N	751311-020	751321-020	751301-020	150 psi Non-Shock Water @ 73°F
	EPDM	752311-020	752321-020	752301-020	
	FKM	753311-020	753321-020	753301-020	
2-1/2	Buna-N	751311-025	751321-025	751301-020	
	EPDM	752311-025	752321-025	752301-025	
	FKM	753311-025	753321-025	753301-025	
3	Buna-N	751311-030	751321-030	751301-030	
	EPDM	752311-030	752321-030	752301-030	
	FKM	753311-030	753321-030	753301-030	
4	Buna-N	751311-040	751321-040	751301-040	
	EPDM	752311-040	752321-040	752301-040	
	FKM	753311-040	753321-040	753301-040	
6	Buna-N	751311-060	751321-060	751301-060	
	EPDM	752311-060	752321-060	752301-060	
	FKM	753311-060	753321-060	753301-060	
8	Buna-N	751311-080	751321-080	751301-080	
	EPDM	752311-080	752321-080	752301-080	
	FKM	753311-080	753321-080	753301-080	

¹: For CPVC EPDM & FKM valves, add the letter "C" to part numbers listed (e.g., 752311-030C).

Sample Engineering Specification

All thermoplastic valves shall be Wafer Butterfly type constructed from PVC Type I Cell Classification 12454 or CPVC Type IV Cell Classification 23447. All valve seats and O-rings shall be Buna-N, EPDM or FKM. Seat shall be a non-liner type mounted to the valve disc. All valves shall have built-in Santoprene™ Thermoplastic Elastomer (TFE) flange gaskets. Wafer style valves shall be for mounting between two flanges having bolt hole pattern that conform to ANSI/ASME B16.5 CL 150. Disc shall be centered with Type 316L Stainless Steel Stem. Stem shall be isolated from the process medium for dry operation. Lever operated valves shall be equipped with high impact polypropylene handle having 7-position stops and built-in lockout capability. Gear operated valves shall be equipped with position indicator and high impact polypropylene handwheel. Valves shall be pressure rated at 150 psi for water at 73°F, as manufactured by Spears® Manufacturing Company.

Features - PVC, CPVC

Spears® Wafer Butterfly Valve is a multi-featured design incorporating laying lengths that allow direct replacement of common Cast Iron valves such as Keystone Model 228 and Bray Series 30 Butterfly Valves. Wafer Valves feature built-in Santoprene™ Thermoplastic Elastomer (TPE) flange gaskets, easy operating disc-mounted seat, and fully isolated stem design. Available in sizes 2" through 8", with choice of Buna-N, EPDM or FKM Seats.

- Chemical & Corrosion Resistant PVC or CPVC Construction
- Special Designed Laying Lengths for Direct Replacement of Common Cast Iron Butterfly Valves
- Built-in Santoprene™ Thermoplastic Elastomer (TPE) Gaskets on Valve Flange Faces
- Easy Operating Disc Mounted Seat in Choice of Buna-N, EPDM, or FKM
- Fully Isolated (Dry) Solid Type 316L Stainless Steel Stem
- Reversible High Impact Polypropylene Lever Handle with 7-Position Stops and Built-in Lockout Capability
- Optional High Efficiency Gear Operator with Cast Aluminum Housing, Polypropylene Handwheel and Built-in Position Indicator
- Compatible with ANSI/ASME B16.5 Class 150 Bolt Pattern Flanges
- Pressure Rated to 150 psi for water @ 73°F (23°C)

General Installation Information

Spears® Wafer Butterfly Valves are designed for system connections between two flanges having ANSI B16.5 Class 150 bolt hole patterns. The valve handle (or gear operator) is reversible 180° for either left or right side operation. Wafer Butterfly Valves have built-in flange gaskets and are designed for installation with user supplied hex bolts, nuts and flat washers. The valve must be positioned with gasket areas evenly located between mating flange sealing surfaces. Valve Bolt Specification bolt lengths in table below are minimums based on use of two (2) Spears® flanges, Valve with built-in gaskets, standard S.A.E. hex bolts and Standard Plate "W" Series flat washers.

Caution: Spears® Wafer Butterfly Valves are designed for use with flanges or flanged equipment having minimum waterway inside diameter no less than that of Schedule 80 PVC pipe (ASTM D 1785). *Use of smaller inside diameter flange connections may result in obstruction and damage to the valve disc and seat.*

WAFER BUTTERFLY VALVES

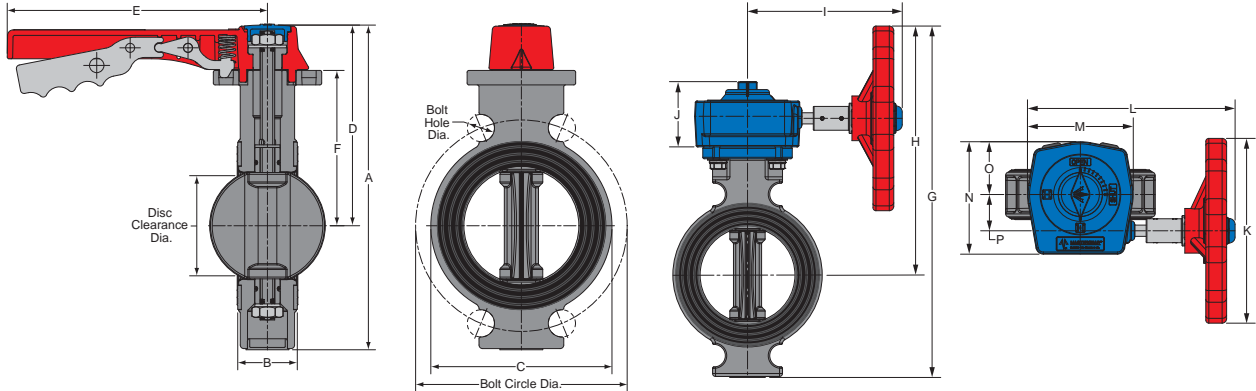

PVC & CPVC Wafer Butterfly Valve Bolt Specifications & Dimensions

Valve Size	Bolt Diameter (in.)	Bolt Length (in.)	No. of Bolt Holes
2	5/8	4-1/2	4
2-1/2	5/8	5	4
3	5/8	5	4
4	5/8	5-1/2	8
6	3/4	6	8
8	3/4	6-1/2	8

Size	A	B	C	D	E	F	Bolt Circle Dia.	No. of Bolts ¹	Bolt Hole Dia.	Disc Clearance Dia.
2	8-5/8	1-11/16	3-3/4	5-9/16	9	4	4-13/16	4	13/16	1-1/2
2-1/2	9-5/8	1-13/16	4-1/2	6-1/16	9	4-1/2	5-9/16	4	13/16	1-15/16
3	10-1/8	1-13/16	5	6-7/16	9	4-7/8	6-1/8	4	7/8	2-3/4
4	11-13/16	2-1/16	6-1/4	6-15/16	9	5-3/8	7-5/16	4 (8)	15/16	3-7/16
6	14-7/8	2-3/16	8-9/16	9-3/8	11-7/8	7-1/8	9-7/16	4 (8)	7/8	5-7/16
8	17-7/16	2-9/16	10-3/4	10-5/8	13-13/16	8-7/16	11-11/16	4 (8)	15/16	7-3/16

1: Valve is positioned with 4 of 8 required Flange Bolts in sizes 4 to 8 inches.

Size	G	H	I	J	K	L	M	N	O	P
2	12-1/4	9-1/8	6-1/2	2-3/4	8	8-3/4	4-1/2	4-3/4	2-1/4	1-1/2
2-1/2	13-1/8	9-1/2	6-1/2	2-3/4	8	8-3/4	4-1/2	4-3/4	2-1/4	1-1/2
3	13-5/8	10	6-1/2	2-3/4	8	8-3/4	4-1/2	4-3/4	2-1/4	1-1/2
4	14-3/4	10-1/2	6-1/2	2-3/4	8	8-3/4	4-1/2	4-3/4	2-1/4	1-1/2
6	17-3/4	12-1/4	6-1/2	2-3/4	8	8-3/4	4-1/2	4-3/4	2-1/4	1-1/2
8	20-3/8	13-1/2	6-1/2	2-3/4	8	8-3/4	4-1/2	4-3/4	2-1/4	1-1/2

Temperature Pressure Rating

System Operating Temperature °F (°C)		100 (38)	110 (43)	120 (49)	130 (54)	140 (60)	150 (66)	160 (71)	170 (77)	180 (82)	190 (88)	200 (93)	210 (99)
Valve Pressure Rating psi (MPa)	PVC	150 (1.03)	135 (.93)	110 (.76)	75 (.52)	50 (.34)	0- (-0-)	0- (-0-)	0- (-0-)	0- (-0-)	0- (-0-)	0- (-0-)	0- (-0-)
	CPVC	150 (1.03)	140 (.97)	130 (.90)	120 (.83)	110 (.76)	100 (.70)	90 (.62)	80 (.55)	70 (.48)	60 (.41)	50 (.34)	0- (-0-)

NOT FOR DISTRIBUTION OF COMPRESSED AIR OR GASES